



ULTRACONGELADOR BK+5

MARCA:

TECNOMAC

PROCEDENCIA:

ITALIA

FUNCIÓN:

Abatir y ultracongelar en el menor tiempo posible, preservando la estructura y propiedades del producto.

CARACTERÍSTICAS:

- Panel de control de tacto suave.
- Abatimiento suave
- Abatimiento duro.
- Congelación de choque.
- Aspas del ventilador anticorrosión.
- Sonda de núcleo.
- Puerta reversible.



DIMENSIONES:

(Dimensiones externas):

Ancho: 800 mm

Largo: 700 mm

Alto: 900 mm

(Dimensiones internas):

Ancho: 660 mm

Largo: 416 mm

Alto: 391 mm

PESO:

106 / 117 Kg

ALIMENTACIÓN:

220 V / 60 Hz.

WATTS:

1250 Watts

Equipos y Servicios de Calidad
para la industria de Alimentos

 citalsa.com
 316 876 6110
   

ULTRACONGELADOR BK+5

ASPECTOS TÉCNICOS:

Capacidad:
5 Bandejas GN 1/1 ó latas 600x400mm

Gas refrigerante:
R452A (GWP2141) -1200 g

Tipo de compresor:
Hermético



18 kg



10 kg

+90°C → +3°C

+90°C → -18°C

ABATIMIENTO

ULTRACONGELACIÓN

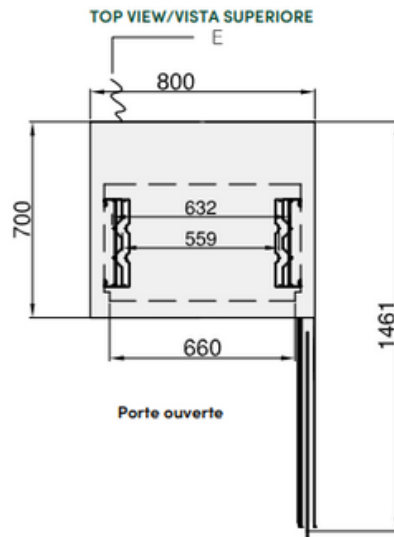
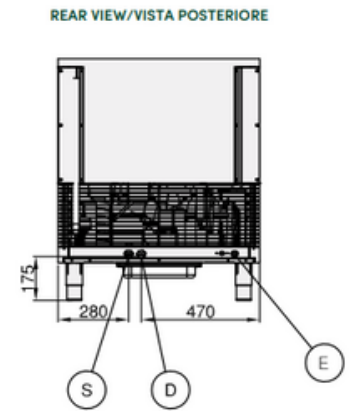
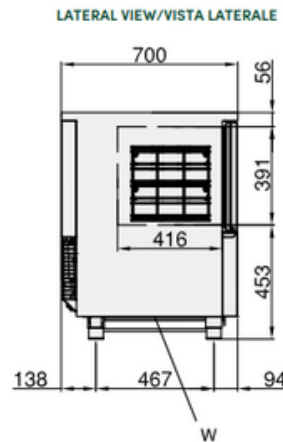
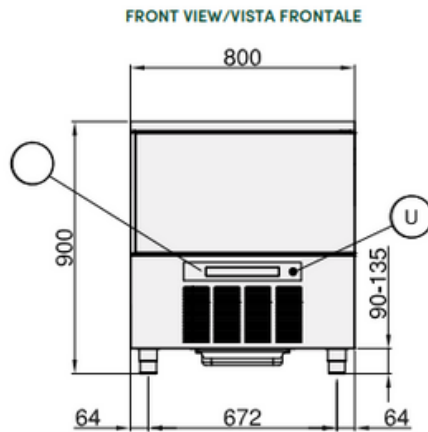

ULTRACONGELADOR BK+5

INTERFAZ TOUCH:

